



Vehicle History Report

2017 SUBARU OUTBACK 2.5I TOURING

VIN: 4S4BSATC5H3313811
4 DOOR WAGON/SPORT UTILITY
2.5L H4 F SOHC 16V
GASOLINE
ALL WHEEL DRIVE

Durani Auto Inc.



Branded Title: Salvage



6 Service history records



3 Previous owners



Personal vehicle



Last owned in California



36,324 Last reported odometer reading

This CARFAX Vehicle History Report is based only on information supplied to CARFAX and available as of 10/16/24 at 11:54:23 PM (CDT). Other information about this vehicle, including problems, may not have been reported to CARFAX. Use this report as one important tool, along with a vehicle inspection and test drive, to make a better decision about your next used car.



Accident / Damage History

Not all accidents / issues are reported to CARFAX

Event 1

10/14/2019

Damage reported: minor damage

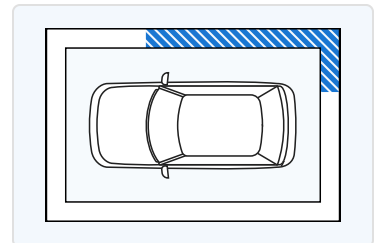
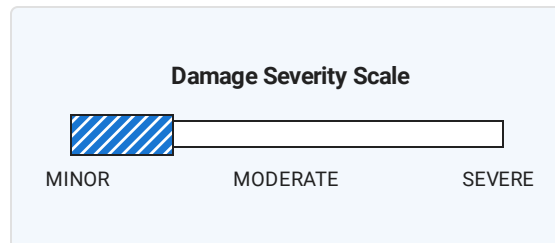

Event 2

04/13/2024

Accident reported: severe damage

- It hit a stationary object
- Vehicle towed
- Airbag deployed

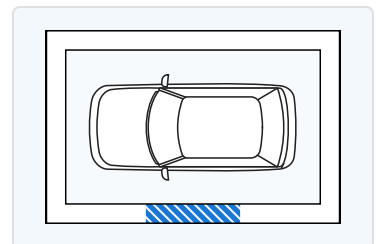
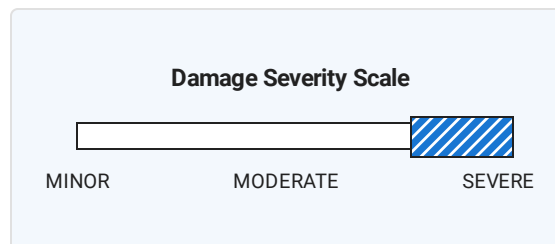

Event 3

06/24/2024

TOTAL LOSS VEHICLE



Additional History

Not all accidents / issues are reported to CARFAX

	Owner 1	Owner 2	Owner 3
Total Loss Total Loss Reported: 06/24/2024.	✔ No Issues Reported	✔ No Issues Reported	Total Loss Reported
Structural Damage CARFAX recommends that you have this vehicle inspected by a collision repair specialist.	✔ No Issues Reported	✔ No Issues Reported	✔ No Issues Reported
Airbag Deployment Airbag deployment reported: 04/13/2024.	✔ No Issues Reported	✔ No Issues Reported	Airbag Deployment
Odometer Check No indication of an odometer rollback.	✔ No Issues Indicated	✔ No Issues Indicated	✔ No Issues Indicated
Accident / Damage DMV title problems reported. Damage reported: 10/14/2019. Accident reported: 04/13/2024.	Damage Reported	No New Issues Reported	Severe Damage
Manufacturer Recall No open recalls reported to CARFAX.	✔ No Recalls Reported	✔ No Recalls Reported	✔ No Recalls Reported
Basic Warranty Original manufacturer warranty likely voided by manufacturer.	✔ Warranty Active	✔ Warranty Active	Warranty Voided



Title History

	Owner 1	Owner 2	Owner 3
Damage Brands Salvage Junk Rebuilt Fire Flood Hail Lemon	No Problem	No Problem	Alert! Problem Found
Odometer Brands Not Actual Mileage Exceeds Mechanical Limits	No Problem	No Problem	No Problem



ALERT! - Severe problems were reported by a state Department of Motor Vehicles (DMV). This vehicle does not qualify for the CARFAX Buyback Guarantee.



Ownership History

The number of owners is estimated

	Owner 1	Owner 2	Owner 3
Year purchased	2017	2021	2022
Type of owner			

Estimated length of ownership	Personal 3 yrs. 11 mo.	Personal 10 months	Personal 2 years
Owned in the following states/provinces	Montana	California	California
Estimated miles driven per year	5,031/yr	--	5,949/yr
Last reported odometer reading	17,825	23,984	36,324

CARFAX Detailed History

 **Owner 1** Purchased: 2017 Personal Vehicle
5,031 mi/yr

Date	Mileage	Source	Comments
07/05/2017		Montana Motor Vehicle Dept.	Vehicle purchase reported - Titled or registered as personal vehicle
08/07/2017	22	Montana Motor Vehicle Dept. Hamilton, MT Title #AA3631090	Title or registration issued - First owner reported - Loan or lien reported - Vehicle color noted as White
08/14/2018		Montana Motor Vehicle Dept. Hamilton, MT Title #AA3631090	Registration issued or renewed - Loan or lien reported - Vehicle color noted as White
08/07/2019		Montana Motor Vehicle Dept. Hamilton, MT Title #AA3631090	Registration issued or renewed - Loan or lien reported - Vehicle color noted as White

10/14/2019 Damage Report

 **Damage reported: minor damage**
- Damage to right rear
- Damage to right side

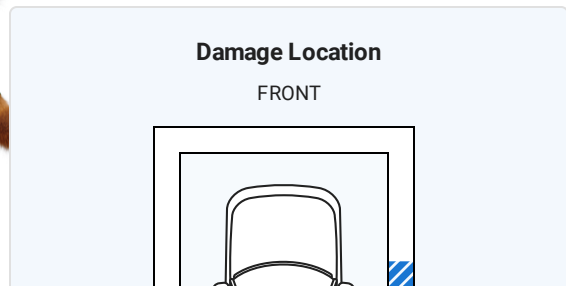
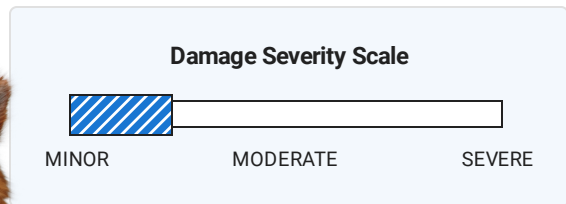

ACCIDENT & DAMAGE INFORMATION

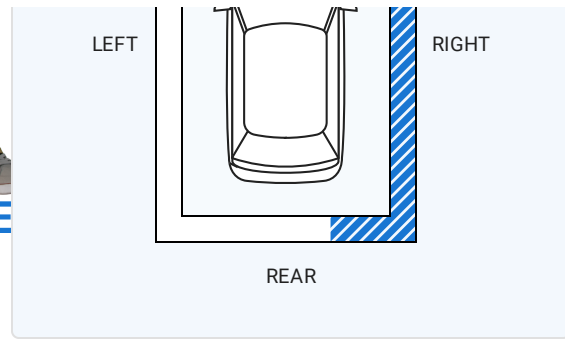

08/11/2020		Montana Motor Vehicle Dept. Hamilton, MT Title #AA3631090		Registration issued or renewed - Loan or lien reported - Vehicle color noted as White
01/07/2021	17,621	Cypress Coast Subaru Mazda Seaside, CA 831-394-8500 cypresscoastsubaru.com ★ 4.9 / 5.0 251 Verified Reviews ❤️ 3,267 Customer Favorites		Vehicle serviced - Maintenance inspection completed - Tire condition and pressure checked - Battery/charging system checked - Brakes checked - Tire repaired
01/18/2021	17,825	Cypress Coast Subaru Mazda Seaside, CA 831-394-8500 cypresscoastsubaru.com ★ 4.9 / 5.0 251 Verified Reviews ❤️ 3,267 Customer Favorites		Vehicle serviced - Maintenance inspection completed - Tire condition and pressure checked - Battery/charging system checked - Oil and filter changed - Brakes checked - Window(s) checked - Window motor(s) replaced - Window regulator(s) replaced
	Owner 2 Purchased: 2021			Personal Vehicle
Date	Mileage	Source		Comments
06/22/2021	19,300	California Motor Vehicle Dept. Carmel, CA		Title issued or updated - New owner reported
02/03/2022	23,269	Cypress Coast Subaru Mazda Seaside, CA 831-394-8500 cypresscoastsubaru.com ★ 4.9 / 5.0 251 Verified Reviews ❤️ 3,267 Customer Favorites		Vehicle serviced - Maintenance inspection completed - Tire condition and pressure checked - Brakes checked - Oil and filter changed
04/27/2022	23,946	Cypress Coast Ford		Vehicle offered for sale

Lincoln
Seaside, CA

★ 4.3 / 5.0

93 Verified Reviews

♥ 1,527 Customer Favorites

05/19/2022 23,950

Cypress Coast Subaru
Mazda
Seaside, CA
831-394-8500
cypresscoastsubaru.com



Vehicle serviced

- Pre-delivery inspection completed
- Maintenance inspection completed
- Tire condition and pressure checked
- Battery serviced
- Brake fluid flushed/changed
- Oil and filter changed

★ 4.9 / 5.0

251 Verified Reviews

♥ 3,267 Customer Favorites

05/25/2022

Val Strough Honda
Seaside, CA
831-899-2222
valstroughhonda.com



Vehicle serviced

- Emissions inspection performed

★ 4.9 / 5.0

192 Verified Reviews

♥ 3,089 Customer Favorites

05/25/2022 23,984

California
Inspection Station

Passed emissions inspection

Owner 3
Purchased: 2022

Personal Vehicle
5,949 mi/yr





Date	Mileage	Source	Comments
05/26/2022	23,985	California Motor Vehicle Dept. Seaside, CA	Odometer reading reported
06/07/2022		California Motor Vehicle Dept. Seaside, CA	Title issued or updated - New owner reported - Loan or lien reported
03/16/2023	30,083	Cypress Coast Subaru Mazda Seaside, CA 831-394-8500 cypresscoastsubaru.com ★ 4.9 / 5.0 251 Verified Reviews ♥ 3,267 Customer Favorites	Vehicle serviced - Maintenance inspection completed - Tire condition and pressure checked - Battery/charging system checked - Brakes checked
04/13/2024		Damage Report	Accident reported: severe damage - It hit a stationary object - Damage to left side Vehicle towed

- Airbag deployed
CARFAX Airbag Tips

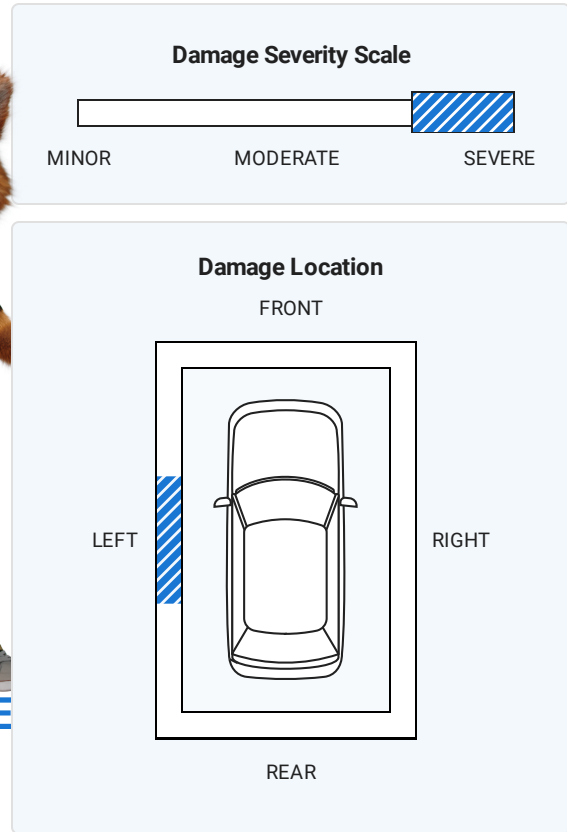

ACCIDENT & DAMAGE INFORMATION



05/30/2024	California Motor Vehicle Dept. Seaside, CA	Title issued or updated - Loan or lien reported
06/21/2024	36,324 California Motor Vehicle Dept. Rancho Cordova, CA	Odometer reading reported
06/24/2024	Damage Report	 TOTAL LOSS VEHICLE
		<div style="border: 1px solid blue; padding: 5px;"><p>There are many reasons an insurance company will declare a vehicle a total loss. Have this vehicle inspected by a qualified technician before you buy. Learn More</p></div>
06/24/2024	California Motor Vehicle Dept.	Title or registration issued to insurance company
06/24/2024	California Motor Vehicle Dept. Rancho Cordova, CA	 Dealer took title of this vehicle while it was in inventory - SALVAGE TITLE/CERTIFICATE ISSUED
06/27/2024	Damage Report	 SALVAGE TITLE/CERTIFICATE ISSUED

Have Questions? Consumers, please visit our Help Center at www.carfax.com. Dealers or Subscribers, please visit our Help Center at www.carfaxonline.com.



Accident Indicator

CARFAX receives information about accidents in all 50 states, the District of Columbia and Canada.

Not every accident is reported to CARFAX. As details about the accident become available, those additional details are added to the CARFAX Vehicle History Report. CARFAX recommends that you have this vehicle inspected by a qualified mechanic.

- According to the National Safety Council, Injury Facts, 2021 edition, 5% of the 276 million registered vehicles in the U.S. were involved in an accident in 2019. Over 77% of these were considered minor or moderate.
- This CARFAX Vehicle History Report is based only on information supplied to CARFAX and available as of 10/16/24 at 11:54:23 PM (CDT). Other information about this vehicle, including problems, may not have been reported to CARFAX. Use this report as one important tool, along with a vehicle inspection and test drive, to make a better decision about your next used car.

Airbag Deployment

Occurs when the driver, passenger or side airbag has been used or deployed during a crash or other incident. If an airbag has been deployed, it must be replaced by a qualified technician. Have this car inspected by a mechanic prior to purchase.

Damage Indicator

Damage can be a result of many different types of events. Examples include contact with objects (other cars, trees, traffic signs, road debris, etc), vandalism, or weather-related events. Not every damage event is reported to CARFAX. As details about the damage event become available, those additional details are added to the CARFAX Vehicle History Report. CARFAX recommends that you have this vehicle inspected by a qualified mechanic.

- This CARFAX Vehicle History Report is based only on information supplied to CARFAX and available as of 10/16/24 at 11:54:23 PM (CDT). Other information about this vehicle, including problems, may not have been reported to CARFAX. Use this report as one important tool, along with a vehicle inspection and test drive, to make a better decision about your next used car.

Damage Severity

Damage events result in one of the following severity levels:

- Minor: Generally, minor damage is cosmetic (including dents or scratches), may only require reconditioning, and typically does not compromise a vehicle's operation and/or safety.
- Moderate: Moderate damage may affect multiple components of the vehicle and may impair the vehicle's operation and/or safety.
- Severe: Severe damage usually affects multiple components of the vehicle and is likely to compromise the vehicle's operation and/or safety.

CARFAX recommends getting a pre-purchase inspection at a certified collision repair facility.

First Owner

When the first owner(s) obtains a title from a Department of Motor Vehicles as proof of ownership.

New Owner Reported

When a vehicle is sold to a new owner, the Title must be transferred to the new owner(s) at a Department of Motor Vehicles.

Ownership History

CARFAX defines an owner as an individual or business that possesses and uses a vehicle. Not all title transactions represent changes in ownership. To provide estimated number of owners, proprietary technology analyzes all the events in a vehicle history. Estimated ownership is available for vehicles manufactured after 1991 and titled solely in the US including Puerto Rico. Dealers sometimes opt to take ownership of a vehicle and are required to in the following states: Maine, Massachusetts, New Jersey, Ohio, Oklahoma, Pennsylvania and South Dakota. Please consider this as you review a vehicle's estimated ownership history.

Salvage Title

A Salvage Title is issued on a vehicle damaged to the extent that the cost of repairing the vehicle exceeds approximately 75% of its pre-damage value. This damage threshold may vary by state. Some states treat Junk titles the same as Salvage but the majority use this title to indicate that a vehicle is not road worthy and cannot be titled again in that state. The following eleven states also use Salvage titles to identify stolen vehicles - AZ, FL, GA, IL, MD, MN, NJ, NM, NY, OK and OR.

Title Issued

A state issues a title to provide a vehicle owner with proof of ownership. Each title has a unique number. Each title or registration record on a CARFAX report does not necessarily indicate a change in ownership. In Canada, a registration and

bill of sale are used as proof of ownership.

Total Loss Vehicle

An insurance or fleet company declares a vehicle a total loss when a claim exceeds approximately 75% of its pre-damage value or if the vehicle is stolen and not recovered. This damage threshold varies by company. These companies typically take possession and obtain the title. Not all total loss vehicles result in a DMV-reported branded title. This may occur when an insurance company's definition of a total loss is different than the state DMV's definition for a branded title or when the owner of the vehicle is a self-insured company, like a fleet or rental company.

Follow Us: facebook.com/CARFAX

[@CARFAXinc](https://twitter.com/CARFAXinc)

 [About CARFAX](#)

CARFAX DEPENDS ON ITS SOURCES FOR THE ACCURACY AND RELIABILITY OF ITS INFORMATION. THEREFORE, NO RESPONSIBILITY IS ASSUMED BY CARFAX OR ITS AGENTS FOR ERRORS OR OMISSIONS IN THIS REPORT. CARFAX FURTHER EXPRESSLY DISCLAIMS ALL WARRANTIES, EXPRESS OR IMPLIED, INCLUDING ANY IMPLIED WARRANTIES OF MERCHANTABILITY OR FITNESS FOR A PARTICULAR PURPOSE.

© 2024 CARFAX, Inc., part of S&P Global. All rights reserved.
10/16/24 11:54:23 PM (CDT)

I have reviewed and received a copy of the CARFAX Vehicle History Report for this 2017 SUBARU OUTBACK vehicle (VIN: 4S4BSATC5H3313811), which is based on information supplied to CARFAX and available as of 10/17/24 at 12:54 AM (EDT).

Customer Signature

Date

Dealer Signature

Date